

THE INTERNATIONAL MOUNTAINEERING AND CLIMBING FEDERATION

UNION INTERNATIONALE DES ASSOCIATIONS D'ALPINISME

Office: Monbijoustrasse 61 • Postfach
CH-3000 Berne 23 • SWITZERLAND
tel.: +41 (0)31 3701828 • fax: +41 (0)31 3701838
e-mail: office@uiaa.ch

	<p>Mountaineering and Climbing Equipment</p> <p>'CONNECTORS / KARABINERS'</p>	<p>UIAA 121</p>
<p style="text-align: center;">Foreword</p> <p>This UIAA Standard is only published in the English language version, which is the master text. For any validations in translation, the UIAA Safety Commission should be contacted via the UIAA Office in Bern, Switzerland.</p> <p>UIAA Standards are the only 'globally recognized' standards for mountaineering equipments. In order to prevent multiplicity, the UIAA collaborates with its partner in standardization CEN; and bases UIAA standard 121 on the European Standard EN 12275:1998. The EN Standards in turn are based on the original UIAA Standards, the first of their kind in the world. Additionally the UIAA publishes pictorials for each of the standards in a user-friendly way. This UIAA Standard 121 also has additional requirements over and above those in EN 12275:1998.</p> <p>Owing to copyright restrictions, this UIAA Standard does not state the full requirements of EN 12275:1998 to which it refers. Hence it is necessary to obtain a copy of EN 12275:1998. The procedure for purchasing the EN Standards is included at the end of the text of this standard. The UIAA Standards are reviewed at intervals to see whether they meet the latest technical requirements and revised if necessary.</p> <p>The UIAA invites manufacturers of mountaineering and climbing equipment worldwide to become members of the UIAA Safety Commission as Safety Label Holders. Members can participate in discussions on standard requirements, test methods and revisions thereof (see the "General Regulations for the UIAA Safety Label").</p> <p>A complete list of UIAA Standards for mountaineering and climbing equipment can be found on the UIAA website.</p> <p>The UIAA Safety Commission, which is responsible for the UIAA Standards, expects that the corresponding EN Standard will be updated to include the additional requirements of the UIAA Standard.</p>		
© 2008 UIAA		
<p>Copyright is secured for the present standard work including all its parts. Any use beyond the limit of the copyright act is forbidden by law.</p> <p>This concerns especially copying, microfilming and feeding and processing in electronic data systems.</p>		

THE INTERNATIONAL MOUNTAINEERING AND CLIMBING FEDERATION

UNION INTERNATIONALE DES ASSOCIATIONS D'ALPINISME

Office: Monbijoustrasse 61 ● Postfach
CH-3000 Berne 23 ● SWITZERLAND
tel.: +41 (0)31 3701828 ● fax: +41 (0)31 3701838
e-mail: office@uiaa.ch

1. General Remarks on the UIAA Trademark and UIAA Label

- 1.1. The UIAA Trademark (see section 5.1.) is copyright protected internationally. The UIAA Label is only given to items of mountaineering and climbing equipment upon approval of prospective label holder's application from the UIAA.
- 1.2. The procedure to be followed by a manufacturer, when applying for a UIAA Label, is laid down in the "General Regulations for the UIAA Safety Label Certification"

2. Requirements for Connectors

- 2.1. The UIAA Label can only be granted for connectors which meet all the requirements of EN 12275:1998, with the following exception:
 - 2.1.1. No EN number required.
- 2.2. For the award of the UIAA Label, the following additional safety requirements shall be met:
 - 2.2.1. Major axis gate-open strength of type K connectors
When tested with the gate opens in accordance with the test method in EN 12275:1998 and 2.2.3. below, type K connectors shall withstand a minimum load of 8 kN.
 - 2.2.2. Strength requirements for type K connectors when loaded over an edge
When tested in accordance with 2.2.4., type K connectors shall withstand a minimum load of 8 kN.
 - 2.2.3. Locked gate strength
 - 2.2.3.1. Locked-gate face-strength
For connectors with a hinged gate and a gate locking device, when tested in accordance with 3.3.1.
 - a) the gate locking device shall remain functional after loading to 1 kN,
 - b) the force required to open the gate to give a 3 mm opening shall be greater than 1 kN.
 - 2.2.3.2. Locked-gate side-strength
For connectors with a hinged gate and a gate locking device, when tested in accordance with 3.3.2,
 - a) the gate locking device shall remain functional after loading to 1 kN,
 - b) the force required to open the gate to give a 3 mm opening shall be greater than 1 kN, whichever side of the connector the load is applied.

3. Tests methods

3.1. Major axis testing, gate-closed and gate-open, of type K connectors
Apply the load to the larger end of the connector using a pin of diameter (16 ± 0.01) mm. All other aspects of the tests shall be as stated in the relevant parts of EN 12275:1998.

3.2. Edge test for type K connectors

3.2.1. Test device

The test apparatus consists of a vertical steel pin of diameter (16 ± 0.1) mm, rigidly mounted above a thick, horizontal steel plate. The horizontal plate has an edge of radius (2 ± 0.1) mm. The distance between the edge and the vertical axis of the pin is (27 ± 0.1) mm. See figure 1, which also specifies other dimensions.

3.2.2. Test method

Clip the larger end of the test sample onto the vertical pin, allowing the auto locking gate to close and lock. Arrange the connector so that its smaller end overhangs the horizontal edge. If the connector is not supplied by the manufacturer with a rope or tape attachment, make such an attachment in accordance with the manufacturer's instructions. Apply a force vertically downwards to the small end of the connector by loading the rope or tape attachment. Apply the force at a speed of 20 to 200 mm/minute. Increase the force to 8 kN and check that the connector has not become detached from the vertical pin. Permanent deformation or fracture of parts of the connector is acceptable.

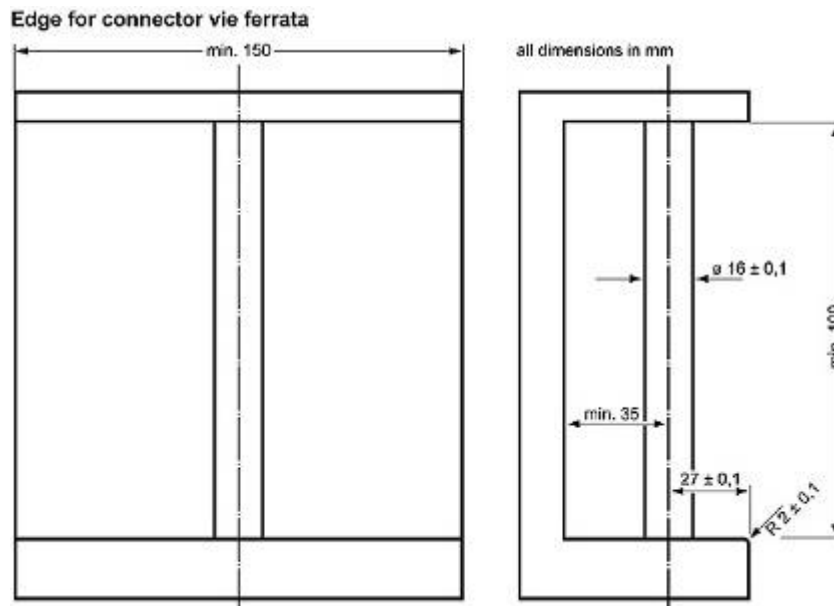
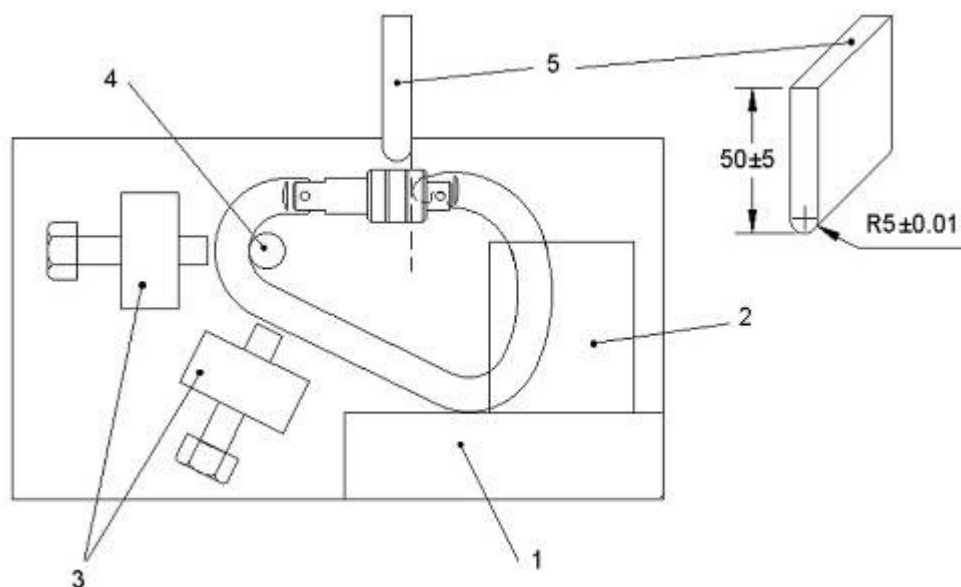

Figure 1 Test Edge for type K connectors

3.3. Locked-gate strength testing

3.3.1. Locked-gate face-strength testing



Key

- 1 Base plate supporting the connector under test.
- 2 Two vertical plates to ensure the connector remain in a vertical plane during the test. These plates may touch the connector body but not grip it.
- 3 Adjustable stops to ensure that this end of the connector does not move during the test.
- 4 Fixed 12mm diameter steel pin.
- 5 Load application tool – see detail for size.

Figure 1 Locked-gate face-strength test

Mount the connector on the base plate of a tensile test machine such that the plane of opening of the gate is vertical, and the locked gate is horizontal (see figure 1). Fix the hinge end of the connector body, using adjustable stops and a 12 mm diameter steel pin, such that it does not move during the test. Support the nose end of the connector body, without gripping it, by metal plates either side of the connector, such that it does not move out of plane during the test. Align the load application tool such that, if the gate of the connector were open, the tool would pass very close to, but without touching, the nose of the connector body. With the connector gate closed and locked, apply an increasing load to the face of the gate with a tool velocity of 20 mm

to 50 mm per minute. When the applied load reaches (1 ± 0.01) kN, hold the load at this value for (30 ± 2) seconds. Raise the tool and check by hand that the gate locking device is still functional. Close and lock the gate, and resume the test. Continue to increase the applied load until the gate opens by at least 3 mm. The gate opening may be checked by using a bar of diameter (3 ± 0.01) mm or by other means. Record the maximum force during the test

3.3.2. Locked-gate side-strength testing

Mount the connector on supports on the base plate of a tensile test machine such that the plane of opening of the gate is horizontal (see figure 2). Support the body of the connector close to the ends of the gate but not touching the gate and not inhibiting the functioning of the gate. Clamp the hinge end of the connector body to the support and testbed as appropriate depending on the shape of the connector body. Align the load application tool (as in 5.3.2.2.5) such that, if the gate of the connector were open, the tool would pass very close to, but without touching, the nose of the connector body. With the connector gate closed and locked, apply an increasing load to the side of the gate with a tool velocity of 20 mm to 50 mm per minute. When the applied load reaches (1 ± 0.01) kN, hold the load at this value for (30 ± 2) seconds. Raise the tool and check by hand that the gate locking device is still functional. Close and lock the gate, and resume the test. Continue to increase the applied load until the gate opens by at least 3 mm. The gate opening may be checked during the test. Record the maximum force during the test.

Repeat this test on a new sample mounted on the other side, using mirror image supports and clamping.

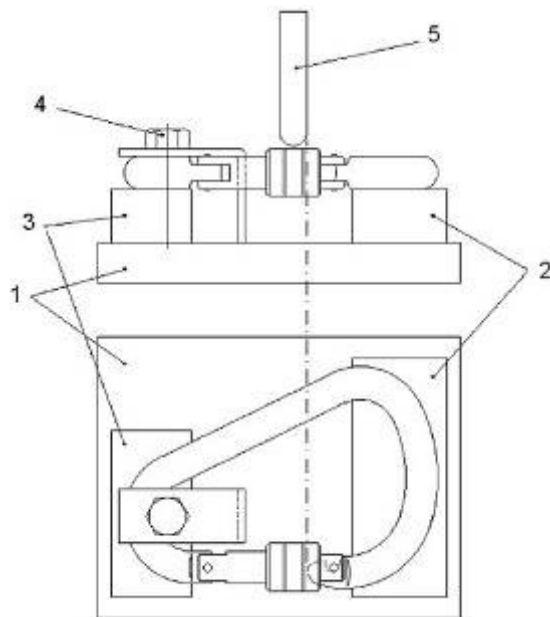

Figure 2 Locked-gate side-strength testing

THE INTERNATIONAL MOUNTAINEERING AND CLIMBING FEDERATION

UNION INTERNATIONALE DES ASSOCIATIONS D'ALPINISME

Office: Monbijoustrasse 61 • Postfach
CH-3000 Berne 23 • SWITZERLAND
tel.: +41 (0)31 3701828 • fax: +41 (0)31 3701838
e-mail: office@uiaa.ch

Key

1. Test bed
2. Support
3. Support & clamp block
4. Clamping bolt
5. Load application tool

3.3.3. Cross-sectional profile.

UIAA 121 and EN 12275:1998 do not specify a minimum dimension for the cross-sectional profile and thickness of connectors in the region in contact with the rope. If the thickness is too small, it will lead to increased wear of the rope in use. Further information is provided in Annex A.

4. Demonstrating that the Requirements are met

- 4.1. The requirements of section 2.1. shall be satisfied by either
 - (a) a test report from a UIAA-approved test laboratory, or
 - (b) a Type Test Certificate from an EU Notified Body, together with any additional documentation or test report which may be necessary.
- 4.2. The requirements of section 2.2 shall be satisfied by the manufacturer certifying on the Safety Label Application Form that the product meets this particular requirement.

5. Information to be supplied

- 5.1. The information to be supplied (in accordance with EN 12275:1998) shall be given in English, or at least in the language of the country in which the product is sold.

6. Attachment of the UIAA Label

- 6.1. For any model of mountaineering equipment, which has been awarded the UIAA Label, the UIAA recommends that the UIAA Trademark (see below) or the four letters "UIAA" be marked clearly and indelibly on each item sold in accordance with the branding guidelines specified in the "General regulations for UIAA Safety Label".



UIAA

- 6.2. In addition, the UIAA Trademark or the four letters "UIAA" may be included in the instructions for use and/or on a swing ticket as well as in catalogues and other publications of the manufacturer. In the last case, the illustration and/or the text must clearly apply only to the equipment which has been awarded the UIAA Label.

Annex A (informative)

Connector cross-sectional profile and thickness

Neither the cross-sectional profile and thickness, nor the curvature of the connector surface in the region that comes in contact with the rope under load is specified in UIAA 121 or EN 12275.

One example of a good profile design in this region is shown in the figure. Depending on the method of manufacture, there will be irregularities in the cross-section such that a perfect radial profile can not be achieved. It is also difficult to specify the region over which the minimum thickness of 8 mm should be maintained. If the thickness and/or the radius of curvature are too small, it will lead to increase wear of the rope in use. Manufacturers of connectors are hereby advised to design connectors with this example of good profile design in mind.

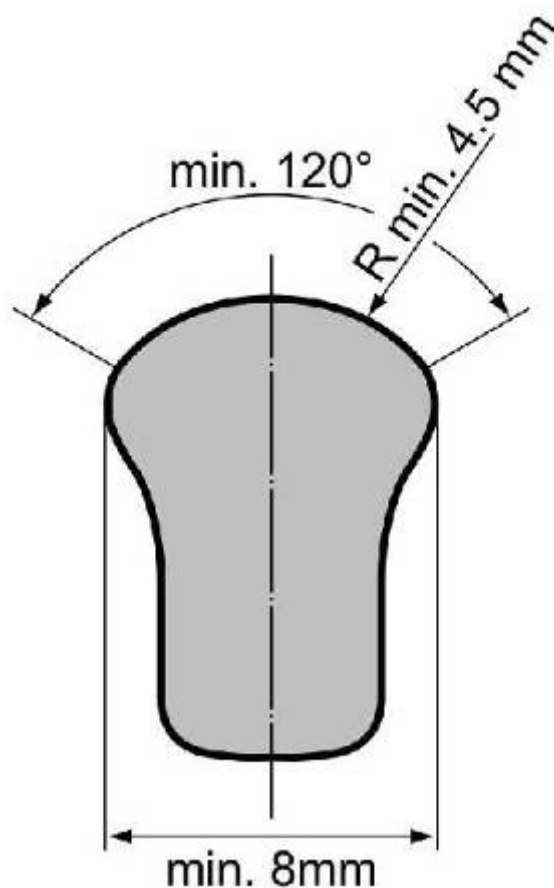

THE INTERNATIONAL MOUNTAINEERING AND CLIMBING FEDERATION

UNION INTERNATIONALE DES ASSOCIATIONS D'ALPINISME

Office: Monbijoustrasse 61 ● Postfach
CH-3000 Berne 23 ● SWITZERLAND
tel.: +41 (0)31 3701828 ● fax: +41 (0)31 3701838
e-mail: office@uiaa.ch

Copies of the EN Standards can be purchased from the following:

Great Britain British Standards Institution (BSI), Tel: +44 20 8996 9001
Order by Fax: +44 20 8996 7001 (with credit card details)
by post: BSI Customer Services c/o Cash Office,
PO Box 16206, London W4 4ZL (cash with order)

France: Association Francaise de Normalisation (AFNOR),
Serv. "Qualite de la Vie" (SQV), Tour Europe,
F-92049 Paris La Défense CEDEX
TEL: + 33 142 91 55 33 FAX: + 33 142 91 56 56

Germany: Beuth-Verlag GmbH, Burggrafenstrasse 4-10,
D-10787 Berlin
TEL: +49 30 2601 2260 FAX: +49 30 2601 1260

Italy: Ente Nazionale Italiano di Unificazione (UNI),
Via Battistotti Sassi 11/b, I-20133 Milano
TEL: +39 270 0241 FAX: +39 270 106 106

Spain: Asociación Espanola de Normalización y Certificación
(AENOR), Genova 6, E-28004 Madrid
TEL: + 34 14 32 60 00 FAX: + 34 13 10 45 96
