



**Mountaineering and
Climbing Equipment**

'BRAKING DEVICES'

**UIAA
129**

Foreword

This UIAA Standard is only published in the English language version, which is the master text. For any validations in translation, the UIAA Safety Commission should be contacted via the UIAA Office in Bern, Switzerland.

UIAA Standards are the only 'globally recognized' standards for mountaineering equipments. In order to prevent multiplicity, the UIAA collaborates with its partner in standardization, CEN. The EN Standards in turn are based on the original UIAA Standards, the first of their kind in the world. Additionally the UIAA publishes pictorials for each of the standards in a user-friendly way.

The UIAA Standards are reviewed at intervals to see whether they meet the latest technical requirements and revised if necessary.

The UIAA invites manufacturers of mountaineering and climbing equipment worldwide to become members of the UIAA Safety Commission as Safety Label Holders. Members can participate in discussions on standard requirements, test methods and revisions thereof (see the "General Regulations for the UIAA Safety Label").

A complete list of UIAA Standards for mountaineering and climbing equipment can be found on the UIAA website.

The UIAA Safety Commission, which is responsible for the UIAA Standards, expects that CEN will include this UIAA standard into CEN Standards.

© 2008 UIAA

VERSION	UIAA 129_1
LAST UPDATED	September 18, 2009
EFFECTIVE DATE	September 30, 2009

Copyright is secured for the present standard work including all its parts. Any use beyond the limit of the copyright act is forbidden by law.

This concerns especially copying, microfilming and feeding and processing in electronic data systems.

www.theuiaa.org

UIAA, Monbijoustrasse 61, Postfach, CH - 3000 Bern 23, Switzerland

t: +41 31 370 18 28 f: +41 31 370 18 38 e: office@theuiaa.org



1. General Remarks on the UIAA Trademark and UIAA Label

- 1.1. The UIAA Trademark (see section 5.1.) is copyright protected internationally. The UIAA Label is only given to items of mountaineering and climbing equipment after application from the manufacturer.
- 1.2. The procedure to be followed by a manufacturer, when applying for a UIAA Label, is laid down in the General Regulations for the UIAA Label (see also How to Obtain a UIAA Label).

2. Scope

This standard specifies safety requirements and tests methods for braking devices used in mountaineering and climbing for abseiling and/or belaying.

3. Terms and definitions

For the purposes of this standard, the following terms and definitions apply:

3.1. Braking device

Mechanical device, through which the rope passes, which generates forces on the rope in a controllable manner, which oppose movement of the rope through the device.

3.1.1. Manual braking device

Device controlled by hand force applied to the free end of the rope that produces a magnified force in the active rope in a continuous and reversible manner, such that when the force in the free end of the rope is reduced to zero, the force in the active rope becomes negligibly small

3.1.2. Locking assisted braking device

Device which acts as a manual braking device at low rope velocities, but at higher velocities, combined with hand control of the free end of the rope, produces a change in device geometry or in rope geometry, such that the rope movement slows down until arrested.

3.1.3. Abseiling braking device

Braking device which, attached to a person and properly connected to the rope, provides braking and arrest of that person during descent, to an extent determined by the action of the person.

3.1.4. Abseiling braking device with panic function

A braking device that, in response to the reflexive panic response (e.g. excessive clutching and/or release of the device), stops the rope moving through the device during abseiling or lowering thereby preventing uncontrolled rope movement.

3.2. Input-output angle (I/O angle)

Angle (30 ± 5)°, see example in Fig. 2, between the rope entering and leaving the device.

3.3. Attachment opening

The attachment point(s) specified by the manufacturer that allows the attachment of the braking device to a connector (in accordance with UIAA 121) in the belay system.

4. Design

4.1. Shape requirements

4.1.1. All devices shall have an attachment opening of at least 13 mm diameter. The edges of all openings shall be at least as in figure 1 and the total width of the opening shall be a minimum of 2.5 mm.

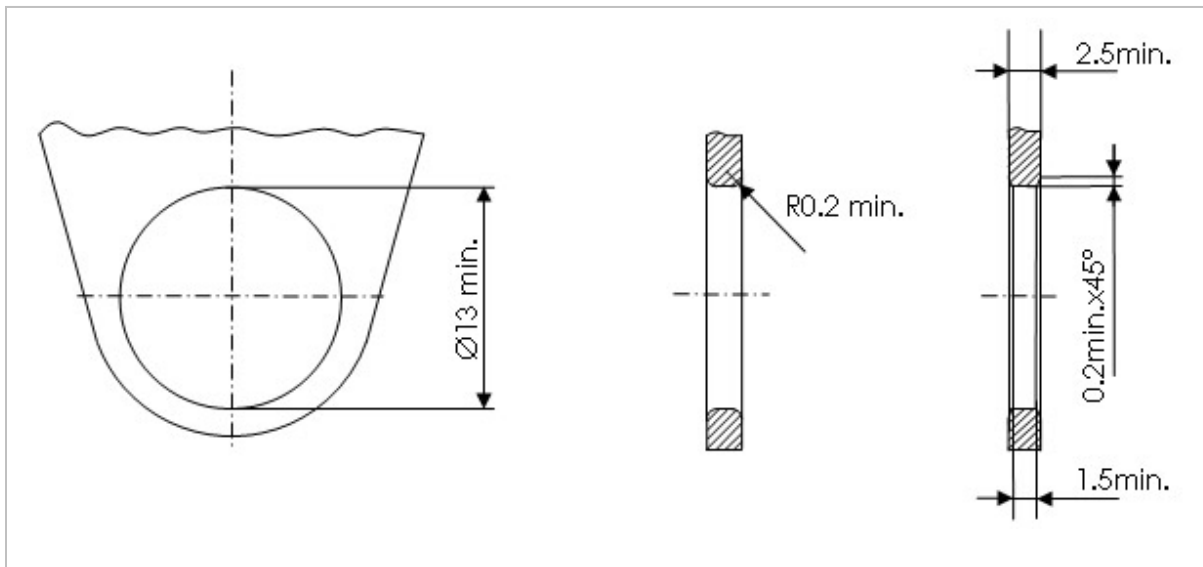

Figure 1: Edges of openings (dimensions in millimeters)

4.1.2. All edges of the device which can come into contact with the user's fingers or the rope shall be free of burrs.

4.2. Shape examination

4.2.1. Determine the dimension of the attachment opening (see 4.1.1) by measuring with a bar of $[13(+0.1/-0)]$ mm diameter.

4.2.2. Test by tactile examination that the edges of the device are free of burrs

5. Strength Test

5.1. Manual Braking Device—device and rope breaking strength

For each attachment point of the device:

Place the device as shown in Figure 2 with an I/O angle of $(30 \pm 5)^\circ$, the rope is inserted as described in the manufacturer's instructions.

Test single rope or half rope (according to UIAA 101) of the minimum diameter acceptable according to manufacturer's instructions. Twin rope shall be tested with 2 strands. The pulling speed shall be (100 ± 30) mm/min.

Reach the load of $[8(+0.5/-0)]$ kN. Maintain the load for (60 ± 10) s.

The device shall not release the loaded rope, shall not show any visible damage, and shall continue to function properly. The rope shall not break.

If more than one braking configuration is described in the manufacturer's instructions, each configuration will be tested with a new rope specimen.

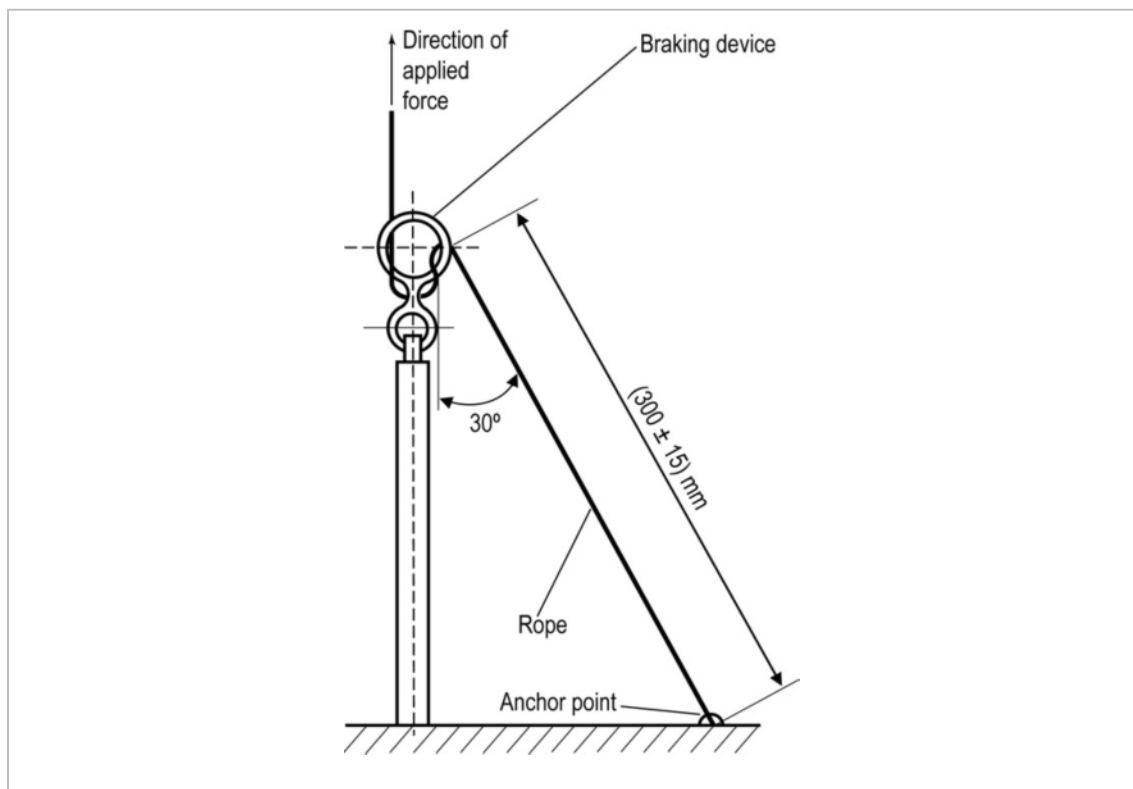

Figure 2: Arrangement for the determination of the device and rope strength.
NOTE – The connection of the device to the structure shall be a swivelling anchor point.

5.2. Locking assisted braking devices—device and rope breaking strength

Use a rope of the minimum diameter specified by the manufacturer. Insert the rope in the braking device according to manufacturer's instruction. Attach the braking device and the end of the rope to a fixed point and a tensile testing actuator; the actuator may be affixed to either the rope end or the braking device. At least 300 mm of rope must be between the device and the rope end as shown in figure 3. Make a stopper knot (figure 4) on the incoming rope and pull it on the other side of the device, with a speed of (100 ± 30) mm/s. Reach a load of $[8(+0.5/-0)]$ kN and maintain this load for (60 ± 10) s.

If necessary, an appropriate stopper plate may be attached above the stopper knot to prevent the knot from slipping through the device (figure 5). Ensure that the design of the stopper device is such that it does not affect the strength of the braking device.

The device shall not release the rope and the device shall continue to function properly. The rope shall not break.

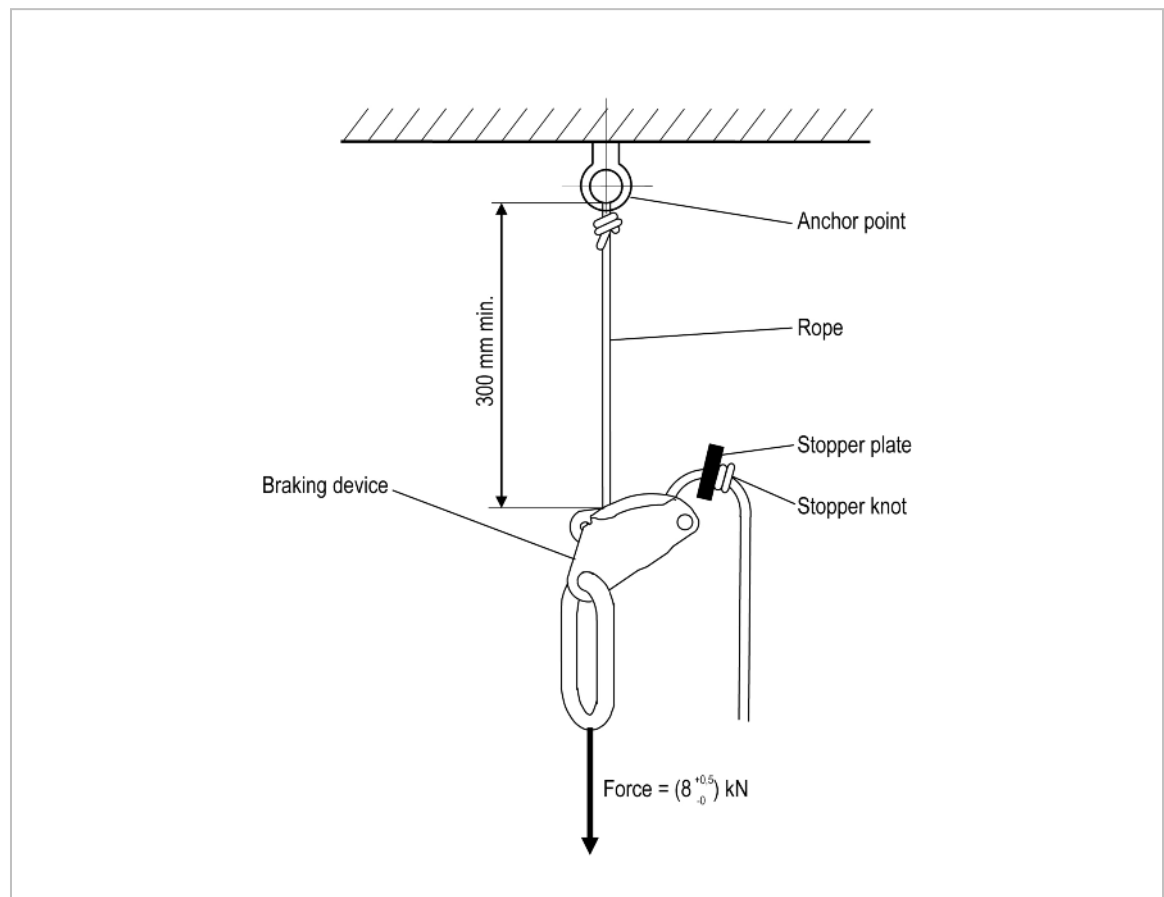

Figure 3: Apparatus for testing static strength of locking assisted braking devices

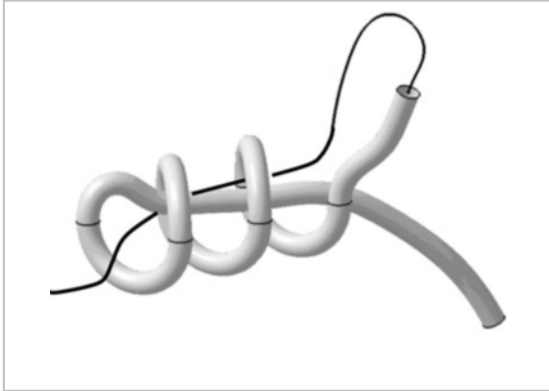

Figure 4: Stopper knot

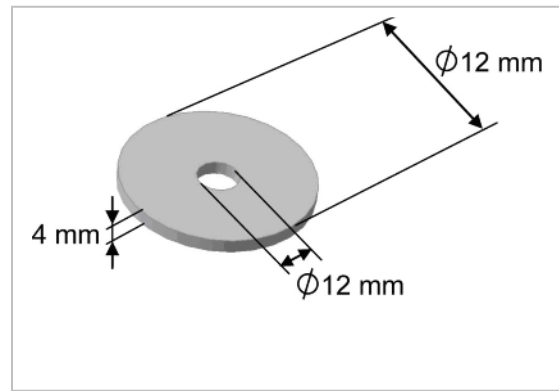

Figure 5: Stopper plate

5.3. Blocking Load–Locking assisted braking device and abseiling device with panic function.

Place the braking device in the test apparatus as shown in figure 6.

Test with ropes of both the minimum and maximum diameters as marked on the braking device, with the device blocked in a hands-free position and/or abseiling panic function engaged, and loaded with a force of $[2^{+0.1/-0}]$ kN. The braking device shall sustain the load for $[3^{+0.1/-0}]$ min with a maximum slippage of 300 mm of the rope through the braking device. After these tests, there shall be no damage to the braking device or to the rope.

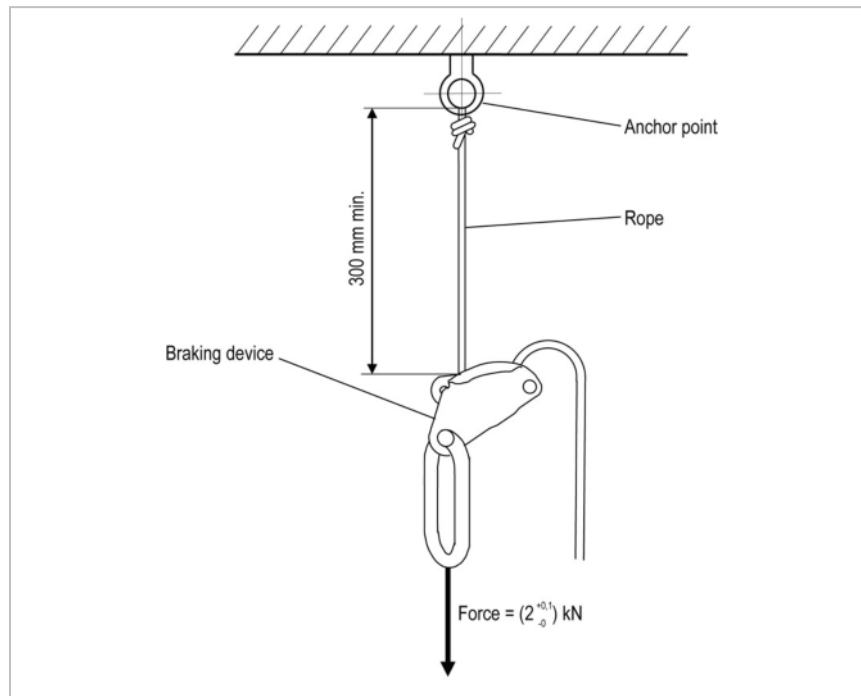

Figure 6: Apparatus for blocking load test

6. Dynamic performance (for locking assisted braking devices only)

6.1. Apparatus

Position the device in a test apparatus as shown in figure 7.

Use a rigid mass of (80 ± 0.1) kg. The mass can be guided (see the apparatus for testing the dynamic ropes UIAA 101) or not guided. If the mass is not guided, the distance between the hanging point of the device and the vertical fall line of the mass shall be less than 300 mm.

Do the test at room temperature, $(20 \pm 5)^\circ\text{C}$.

For the length values there is a tolerance of ± 20 mm unless otherwise noted.

6.2. Procedure

Use a rope with the minimum diameter in the range prescribed by the manufacturer.

Connect the rope to the mass with a figure-of-eight knot. Tighten the knot by hand; the inner length of the eye of the knot shall be (50 ± 10) mm. Lower the mass below the braking device by at least (1200 ± 50) mm. Tighten the knot by weighting the rope with the hanging mass for (60 ± 10) s. Then lift the mass to permit insertion of the rope into the device. Lift the mass to (1000 ± 10) mm above the point where the rope leaves the device. Straighten the rope by pulling it by hand on the other side of the device; ensure that the device is kept in its natural hanging position. Mark the rope where it leaves the device.

The length of the free end of the rope hanging below the device shall be less than 2000 mm.

Release the load. Measure the slippage of the rope through the device, with the mass still hanging, within 60 s after the fall.

After the test, check visually that the test mass is suspended by the braking device. Check that the mass can be lowered to the ground in accordance with the information supplied by the manufacturer.

The slippage of the rope through the device shall not exceed 1500 mm.

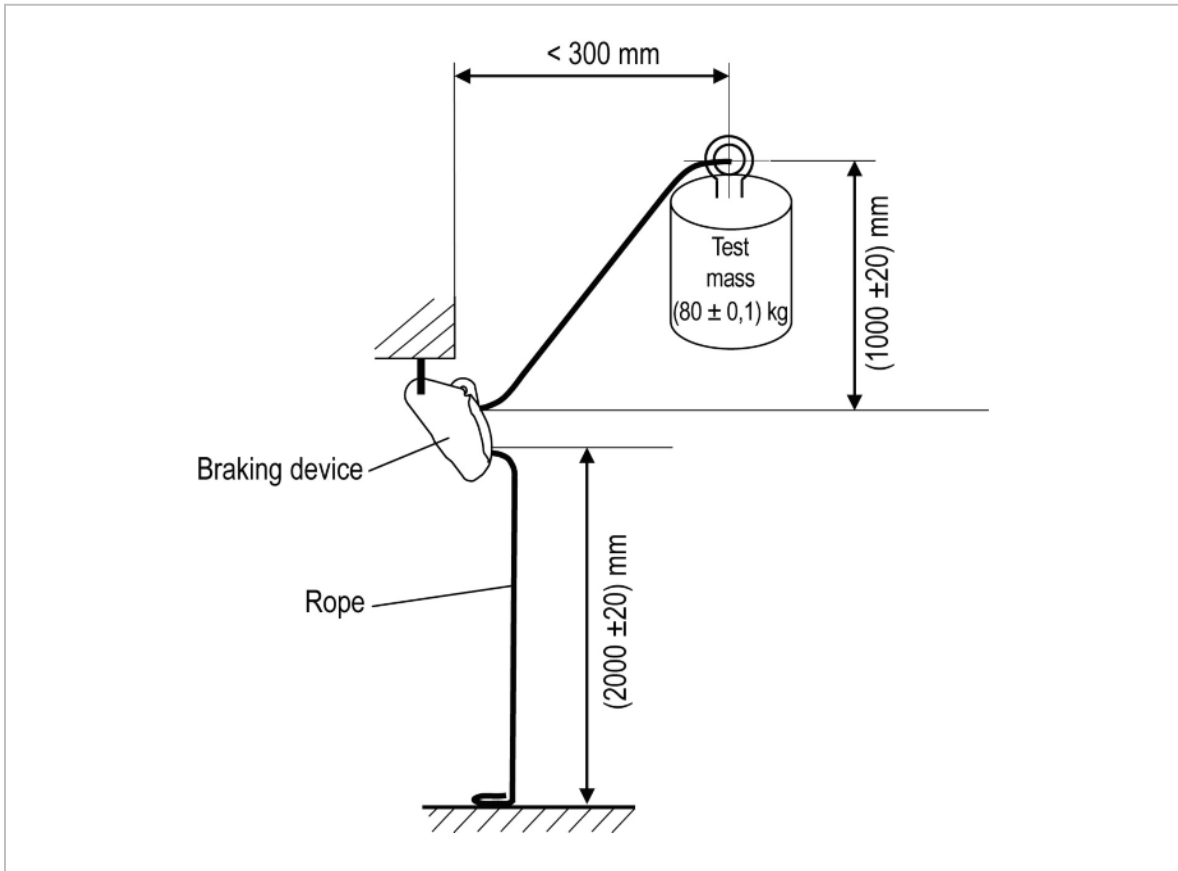

Figure 7: Apparatus for the dynamic performance test

The dynamic performance test may not represent appropriate use of the braking device. The device must always be used according to the manufacturer's instructions, which may prescribe the necessity to always keep a hand on the free end of the rope and forbid the use of the device without a runner between the belayer and the climber.

7. Marking

- 7.1. The braking device shall be marked with at least the following information:
- 7.1.1. the name or trademark of the manufacturer, importer or supplier
 - 7.1.2. for locking assisted braking devices: visual indication of the correct placement of the rope.
 - 7.1.3. a pictogram indicating the necessity of reading the instructions provided by the manufacturer. An example of such a pictogram is shown in figure 8.

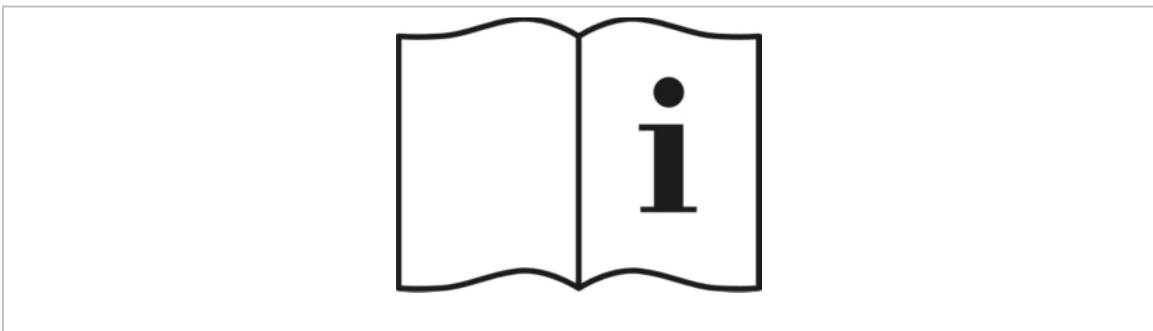

Figure 8: An example of a pictogram indicating that the user must read the instructions provided by the manufacturer.

8. Information to be supplied by the manufacturer

- 8.1. The instructions shall be written at least in the (a) language of the state of destination.
- 8.2. The following information shall be given:
- 8.2.1. name and address of the manufacturer or its representative.
 - 8.2.2. model identification (if more than one model is available)
 - 8.2.3. specification of the possible uses of the device: belaying, abseiling or both
 - 8.2.4. use of the product, especially :
 - a warning specifying that the expected braking action of the device is depending of the rope diameter and the slipperiness of the rope. Prior to real use, a test in a safe situation is recommended.
 - the minimum and maximum rope diameter, in millimetres, to one decimal place, with which the device can be used for the two configuration : one rope (single) and two ropes (half rope and twin rope). E.g.: 1 x Ø 9.2/10.5, 2 x Ø 7.5/8.8
 - for assisted locking devices a prescription that the braking hand must be kept on the free end of the rope at all times, to avoid failure in case of a fall.
 - indication of the correct placement of the rope
 - information about evaluating the effectiveness of the device's operation and withdrawal the device from use if it is not effective.

- 8.2.5. the meaning of any markings on the product
- 8.2.6. for each of the possible uses, instruction about the braking device's attachment to any connection component.
- 8.2.7. how to maintain/service the product
- 8.2.8. lifespan of the product or how to access it and that after a serious damage the product should be withdrawn as soon as possible
- 8.2.9. a warning about possible effects of operation with wet or icy ropes.
- 8.2.10. information on risks specific to this device.

9. Demonstrating that Requirements are met

- 9.1. The safety requirements shall be satisfied by either
 - a) a test report from a UAAA-approved test laboratory, or
 - b) a test report from an EU Notified Body accredited as a UAAA Laboratory.

10. Attachment of the UAAA Label

- 10.1. For any model of mountaineering equipment, which has been awarded the UAAA Label, the UAAA recommends that the UAAA Trademark (see figure 9) or the four letters "UAAA" be marked clearly and indelibly on each item sold in accordance with the branding guidelines specified in the "General regulations for UAAA Safety Label".
- 10.2. In addition, the UAAA Trademark or the four letters "UAAA" may be included in the instructions for use and/or on a swing ticket as well as in catalogues and other publications of the manufacturer. In the last case, the illustration and/or the text must clearly apply only to the equipment which has been awarded the UAAA Label.



Figure 9: UAAA label logos

Copies of the EN Standards can be purchased from the following:

Great Britain British Standards Institution (BSI), Tel: +44 20 8996 9001
Order by Fax: +44 20 8996 7001 (with credit card details)
by post: BSI Customer Services c/o Cash Office,
PO Box 16206, London W4 4ZL (cash with order)

France: Association Francaise de Normalisation (AFNOR),
Serv. "Qualite de la Vie" (SQV), Tour Europe,
F-92049 Paris La Défense CEDEX
TEL: + 33 142 91 55 33 FAX: + 33 142 91 56 56

Germany: Beuth-Verlag GmbH, Burggrafenstrasse 4-10,
D-10787 Berlin
TEL: +49 30 2601 2260 FAX: +49 30 2601 1260

Italy: Ente Nazionale Italiano di Unificazione (UNI),
Via Battistotti Sassi 11/b, I-20133 Milano
TEL: +39 270 0241 FAX: +39 270 152 152

Spain: Asociación Espanola de Normalización y Certificación
(AENOR), Genova 6, E-28004 Madrid
TEL: + 34 14 32 60 00 FAX: + 34 13 10 45 96
