

UIAA 157

Second Edition

May 2026

Effective from

January 2027

Avalanche Rescue Probes **Climbing and Mountaineering Equipment**



International Climbing and Mountaineering Federation
UNION INTERNATIONALE DES ASSOCIATIONS D'ALPINISME

UIAA Safety Standard – 157 – Version 2.0

© 2026 UIAA

c/o Schweizer Alpen-Club SAC, Monbijoustrasse 61, Postfach, CH-3000 Bern 14, Switzerland
+41 31 370 18 28 • www.theuiaa.org • office@theuiaa.org

Table of Contents

Foreword	iii
Copyright and Version Management	iv
Normative References	v
1 General Remarks on the UIAA Trademark and UIAA Label	6
2 Scope	6
3 Terms and Definitions	6
4 Safety Requirements	7
5 Test Methods	8
6 Markings	10
7 Information to be Supplied	10
8 Demonstrating that the Requirements are Met	10
9 Attachment of the UIAA Safety Label	10
Revision History	12

Foreword

UIAA standards are the only ‘globally recognized’ standards for mountaineering equipment.

The UIAA standards are reviewed at intervals to see whether they meet the latest technical requirements and revised if necessary.

The UIAA invites manufacturers of mountaineering and climbing equipment worldwide to become members of the UIAA Safety Commission as Safety Label Holders. Members can participate in discussions on standard requirements, test methods, and revisions thereof (see the “[Regulations for existing and potential Safety Label Holders](#)”).

A complete list of UIAA standards for mountaineering and climbing equipment can be found on the UIAA website www.theuiaa.org/safety-standards/.

This standard has been created and updated based on scientific research coordinated and funded by UIAA, as a service to all mountaineers.

Copyright and Version Management

© 2021 & 2026

This document was first published in English. The English master text is decisive in any conflict of interpretation. For any validations in translation, the UIAA should be contacted via the UIAA Office in Bern, Switzerland.

UIAA declarations, standards, documents and guidelines are subject to review. Updates are recorded in the version history provided at the end of this document.

UIAA documents are generally produced by the responsible Commission and are subject to approval in accordance with the UIAA Articles of Association. All UIAA documents can be found on the relevant subject area on the UIAA website.

This publication may be reproduced by UIAA member federations in any form for non-profit or educational purposes, providing that the source is acknowledged. Other parties are requested to contact the UIAA office for permission.

No use of this publication may be made for resale or any other commercial purpose whatsoever without the prior permission in writing from the UIAA.

Copyright is secured for the present document including all its parts. Any use beyond the limit of the copyright act is forbidden. Copyright of photos and pictorials belong to the UIAA or according to specific credits mentioned.

The versioning is $Vx.y$, where:

- x Major revision of the document. Each change in requirement implies a main evolution.
- y Minor revision of the document. Editorial or non-technical updates.

For example, **V5.0** denotes the fifth major revision of the document.

Note that test reports comprising only the main issue, e.g., V5, are also accepted (instead of, e.g., V5.2) since the requirements are identical.

Normative References

The following documents are referenced in such a way that their content, in whole or in part, constitutes requirements of this standard. For dated references, only the edition cited applies. For undated references, the latest edition (including any amendments) applies.

ISO 2768-1:1989, *General tolerances*

ISO 7000:2019, *Graphical symbols for use on equipment*

1 General Remarks on the UIAA Trademark and UIAA Label

1.1 The UIAA Trademark (see [section 9](#)) is copyright protected internationally. The UIAA Safety Label is only granted to items of mountaineering and climbing equipment upon approval of the prospective label holder's application by the UIAA.

1.2 The procedure to be followed by a manufacturer, when applying for a UIAA Safety Label, is laid down in the "[Regulations for existing and potential Safety Label Holders](#)" available at the [UIAA website](#).

2 Scope

This standard specifies the safety requirements and test methods for avalanche rescue probes used in rescue and snow safety work. Probes are mainly used for the following tasks:

- pinpointing of buried subjects following a search with electronic search devices which allow to find an approximate point of shortest distance on the snow surface,
- surface probing techniques usually applied in probe lines to find buried subjects who are not searchable by any other means,
- in case of avalanche rescue, once a probe hit has been achieved, the probe stays in the debris and acts as an important visual guide for the rescuers during the excavation effort,
- in snow safety work to measure snow depth and as a tool to facilitate snowpack stability measurements.

3 Terms and Definitions

For the purpose of this standard, the following definitions apply:

3.1 Type of Probe Assembling Systems

3.1.1 Tubular probes with a longitudinal locking system holding together all segments are classified as: *foldable* probes.

3.1.2 Probes where each individual segment is connected to the neighbouring segments with a screwing mechanism are classified as: *screwable* probes.

3.2 Nomenclature

3.2.1 *Probe*: All components that comprise, when assembled, a device used to fulfil the scope as outlined in [section 2](#). A probe is a generic term for the hereto known as avalanche rescue probe.

3.2.2 *Segment*: the individual subsections of the probe.

3.2.3 *Tip*: the part of the probe designed to penetrate the snow.

3.2.4 *Nipple*: the insert part of the segments due to join on each other's.

3.2.5 *Foldable* probe assembly system: the locking system holding all segments including the tip of a foldable probe reliably and firmly together.

3.2.6 *Screwable* probe assembly system: the screwing mechanism holding all segments including the tip of a screwable probe reliably and firmly together.

3.3 Geometry

Refer to [Figure 1](#).

3.3.1 *Probe length (L)*: the overall probe length when appropriately assembled.

3.3.2 *Segment length (S)*: the length of a segment of the probe.

3.3.3 *Probe segment diameter (Ds)*: external diameter of a probe segment.

3.3.4 *Probe tip diameter (Dt)*: outside diameter of the probe tip penetrating the snow.

3.3.5 Tip length (L_t): the length of the tip penetrating the snow.

3.3.6 Tip radius (R): radius of the outermost part of the tip that touches the buried subject first.

3.3.7 Nipple Length (L_n): the length of the male part, typically cylindrical, designed to link structurally adjacent segments. Tapering, typically conical, excluded.

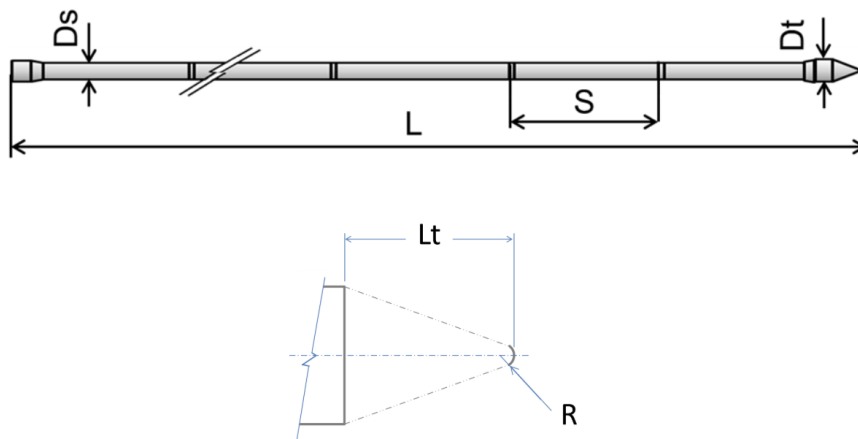

Figure 1: Geometry

4 Safety Requirements

The UIAA Label can only be granted for probes which meet all the following requirements:

4.1 Design and ergonomics

4.1.1 There shall be no accessible shear and squeeze points created by loads applied during normal use that could harm the prober.

4.1.2 Sharp corners, edges, and rough surfaces which can cause minor injuries shall be avoided. Make sure that edges are deburred, beaded, or framed.

4.1.3 The overall probe length L shall be ≥ 240 cm.

4.1.4 The external segment diameter D_s of the probe shall be ≥ 11 mm.

4.1.5 The tip diameter D_t shall be $D_s + 2$ mm to 4 mm.

4.1.6 The tip length L_t shall be 1.6 to $3.2 \times D_s$.

4.1.7 The tip radius R shall be between 1.5 mm and 2 mm.

4.1.8 Foldable probes shall have a well visible metric scale printed on the probe body starting from the tip. The printed scale shall have at least one mark every 5 cm and the penetrating depth in printed numbers at every 10 cm interval. The metric scale print might be interrupted on the last segment (that one normally not fully penetrating the snow) to allow other markings as required per [section 6](#).

4.1.9 All probes shall have the first segment (interfacing with the tip) in a distinctively different colour than all the remaining segments.

4.2 Static Strength

4.2.1 The bending strength of the probe shall be evaluated in accordance with [subsection 5.5](#). The probe shall withstand a 100 N load. Neither permanent deformation nor any sort of material separation is permitted.

4.2.2 The axial strength of the entire assembled probe, evaluated in accordance with [subsection 5.6](#), shall withstand 250 N. No permanent deformations or slippage of the probe assembly system permitted.

4.3 Stiffness

4.3.1 The probe flexural stiffness evaluated in accordance with [subsection 5.5](#) shall be $> 2.5 \text{ N/mm}$.

4.3.2 The probe axial stiffness evaluated in accordance with [subsection 5.6](#) shall exhibit a deflection to nipple length ratio < 0.4 .

4.4 Assembly Effort

The effort required to assemble a probe shall not exceed a force of 100 N for foldable probes or a torque of 5.2 Nm for screwable probes.

5 Test Methods

5.1 Requirements in items 4.1.1 to 4.1.9 shall be verified by means of visual inspection, hands-on inspection, and dimensional measurements to an accuracy consistent with general tolerances specifications from ISO 2768–m.

5.2 A *foldable* probe shall be assembled by locking its system according to the manufacturer/model device instructions. For probes with a dedicated mechanism to adjust the length of the tensioned material, the test must be carried in the configuration the product is (or will be) sold. Apply a pull force equal to 100 N, then release the tension and let the product-specific locking mechanism hold the probe tensioned. For devices requiring a manual action to lock the device, such as for threaded locking mechanisms, follow the specific instructions of the manufacturer.

5.3 A *screwable* probe shall be assembled by hand tightening the screw of the connecting segments, or according to the instructions of the manufacturer.

5.4 Number of tests: each kind of test shall be performed on three (3) samples of each type/model. All the samples must comply with the test acceptance criteria.

5.5 Three Points Bending Test: refer to [Figure 2](#).

5.5.1 *Test apparatus* shall fulfill the following functions and criteria:

- A frame with a pair of rigid supports to span over a series of three segments of the assembled probe.
- The distance between the supports remains 870 mm, independently of the length of the segments of the individual test article.
- The supports shall have a single contact point with the probe, thus allowing its free rotation when deflected. Consider use of bearings (or similar means) with a diameter of 20 mm.
- The frame shall be conceived so that both cantilevered portions of the probe are weight relieved. Consider a horizontal setup with additional weight support close to both the extremities of the probe.

5.5.2 *Test procedure* in chronological order:

- i. Place the assembled probe on the test apparatus so that the load application point is in the centre of the closest central probe segment and mid-span of the two supports.
- ii. Apply a monotonically increasing nominal force $P = 100 \text{ N} \pm 1\%$ at no more than 50 N/min loading rate.
- iii. Measure and record load P (N) and deflection δ (mm) actual pair values.
- iv. Evaluate the probe bending stiffness $K_{\text{flex-}i} = P/\delta$.
- v. Repeat five times steps i. to iv.
- vi. Compute the mean value $K_{\text{flex-ave}} = \sum K_{\text{flex-}i} / 5 \quad i = 1 \div 5$.

5.5.3 *Pass/Fail criteria*:

- The test is passed if $K_{\text{flex-ave}} > 2.5 \text{ N/mm}$.

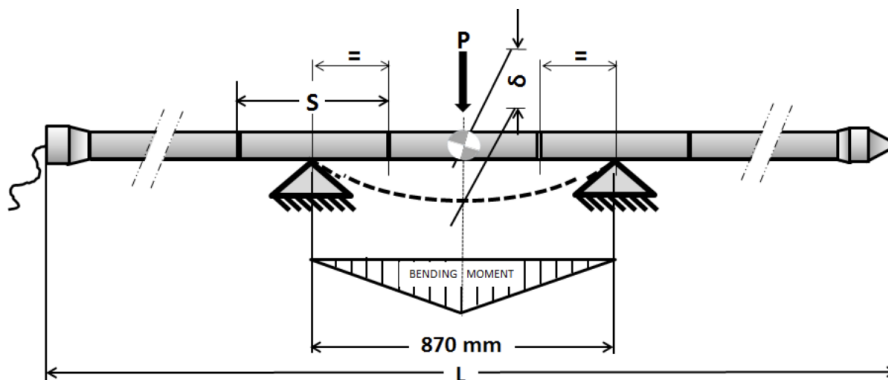

Figure 2: Three Points Bending Test Setup

5.6 Axial Pull Test: refer to Figure 3.

5.6.1 The test applies to *foldable* probes only.

5.6.2 The test may be carried out in a horizontal or a vertical position.

5.6.3 *Test apparatus* shall fulfill the following functions and criteria:

- A frame with specific means to firmly clamp one extreme while pulling coaxially at the opposite one.
- A mid-span simple support is recommended if the test is carried out in a horizontal position.

5.6.4 *Test procedure* in chronological order:

- i. Place and clamp the assembled probe on the test apparatus.
- ii. Apply a monotonically increasing force $P = 250\text{ N} \pm 1\%$ at no more than 100 N/min loading rate.
- iii. Measure and record deflection δ (mm).
- iv. Evaluate the ratio $R_{\text{axial}-i} = \delta / L_n$.
- v. Repeat five times steps i. to iv.
- vi. Compute the mean value $R_{\text{axial-ave}} = \sum R_{\text{axial}-i} / 5 \quad i = 1 \div 5$.

5.6.5 *Pass/Fail criteria*:

- The test is passed if $R_{\text{axial-ave}} < 0.4$.

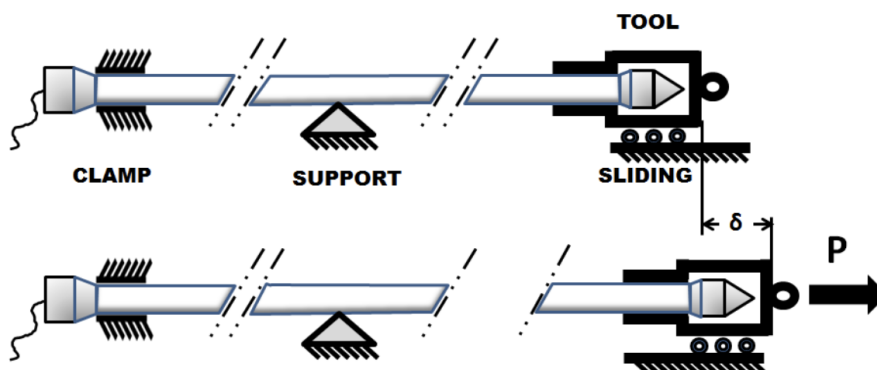

Figure 3: Axial Pull Test

6 Markings

Avalanche rescue probes shall be permanently marked at least with the following information:

- a. Name of the manufacturer or its authorized representative;
- b. Identification of the model if several models are sold by the same manufacturer;
- c. Preferably batch of fabrication, but at least the specific design version of the model. In case of modifications in the mechanical construction, fabrication process or type of materials used, the design version must change;
- d. Graphical symbol (see [Figure 4](#)), which instructs the user to read the information supplied by the manufacturer.

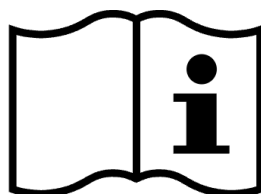

Figure 4: Operator’s Manual (according to ISO 7000, Symbol No. 1641)

7 Information to be Supplied

The “information to be supplied” shall be given in standard English and, if required, in the official language(s) of the country in which the product is sold. As an alternative to a printed form, the information may be provided via an electronic or other data storage format link (e.g., a QR code) allowing to download the information. The information link shall be preceded or surmounted by an icon showing an open booklet; the information link and icon may be directly printed on the product in a clearly visible and accessible place. The avalanche rescue probe shall be supplied with the following information:

- a. Name of the manufacturer or its authorized representative and address;
- b. Reference to this UIAA standard, (i.e., UIAA 157);
- c. Identification of the model if several models are sold by the same manufacturer;
- d. Year of fabrication;
- e. Instructions about the assembling, use, storage, and maintenance;
- f. Information about service life and disposal.

8 Demonstrating that the Requirements are Met

The requirements defined in [section 4](#) shall be satisfied by a test report from a UIAA-approved test laboratory

9 Attachment of the UIAA Safety Label

9.1 Safety Label Marking

For any model of mountaineering equipment, which has been granted the UIAA Safety Label, the UIAA Trade-mark (see [Figure 5](#)) or the four letters “UIAA” shall be marked clearly and indelibly on each item sold in accordance with the branding guidelines specified in the “[Regulations for existing and potential Safety Label Holders](#)”.



Figure 5: UIAA Trademark or the four letters “UIAA” word mark.

9.2 Other

In addition, the UIAA Trademark or the four letters “UIAA” may be included in the instructions for use and/or on a swing ticket as well as in catalogs and other publications of the manufacturer. In the last case, the illustration and/or the text shall clearly apply only to the equipment which has been granted the UIAA Safety Label.

Revision History

May 2026

Formatting, minor clerical orthographic corrections and a more univocal language in item [4.1.8](#).

May 2021

Basic release